

Uniflow-200 in non-standard applications

Case study 1 – flow meter serial test

What does a flow computer do?

Measurement of the quantity of the fluid flowing in pipelines probably one of the most frequent measurement task in industrial applications.

The primary element of the flow metering system (e.g. turbine meter, ultrasonic meter, etc.) measures volume flow rate at line conditions. The flow rate shall be converted to volume flow rate at certain pressure and temperature (at standard reference conditions) or to mass flow rate. It is equally important to calculate the energy flow rate provided by volumetric or mass flow rate of the fluid.

In flow measurement systems, flow computer performs the necessary calculations. Sometimes some simplified set of calculations is embedded into flow meters or multivariable transmitters. However, in the flow measurement systems for custody transfer applications the flow computer is usually a separate device.

A simple measuring system for natural gas flow measurement is shown on the following figure.

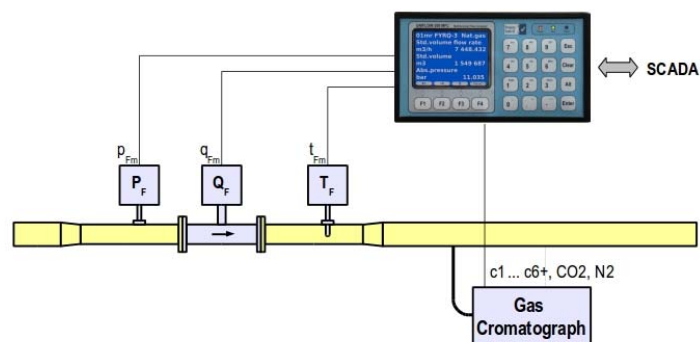

There are many flow computers on the market, capable to perform calculations required in simple measuring system.

In this article I will show a non-standard application which utilize the special features implemented in the Uniflow-200 flow computer manufactured by Process Control Kft, Hungary.

Comparison of two flow meters connected in series

On gas metering stations often found the so-called Z-connection of the meter runs. The essence of this connection is that the fluid stream from the output of one meter run is forwarded to the input of the other meter run. Thus, during the normal operation of the measuring station comparison of the two flow meters is possible.

This solution is more economical than built-in duplicate flow meters in each meter run. Another advantage is that one line can be assigned as a "master" or a spare line. It does not work during normal operation of the station, measures flow only

during the comparison. Thereby preserves the original metrological characteristics, i.e. it is not subject to wear, contamination inherent in normal operation.

The scheme of such a connection is shown in the following figure.

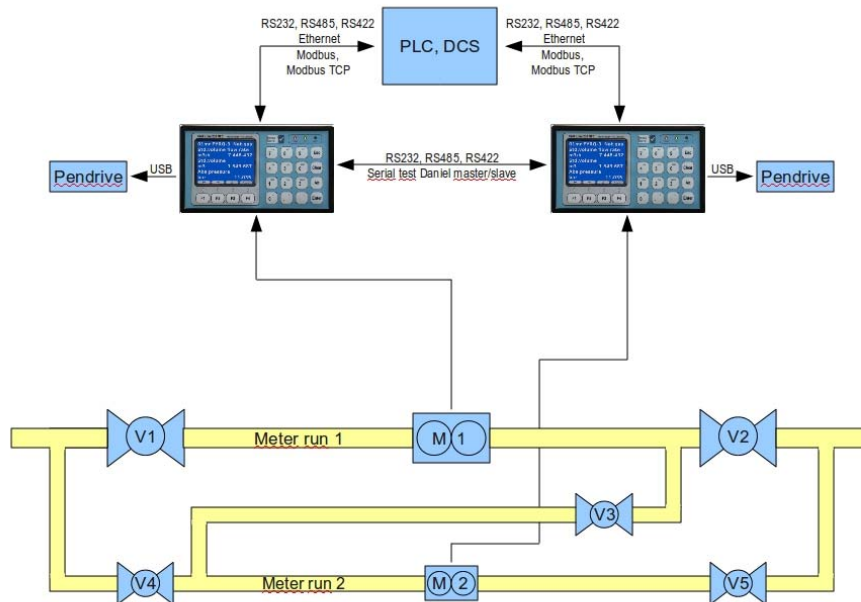

During the serial connection of the meter runs the same fluid flow is measured twice. There are two special issues the flow computer shall take care about them during the comparison:

- how to distinguish between the volumes measured for billing purposes and volumes measured second time for comparison only;
- which one of the flow computers will control the data acquisition and prepare the comparison report.

In Uniflow-200 there are two parameters helping solve the two issues listed above.

One is the custody transfer/non-custody transfer parameter.

If it is set to “custody transfer” then flow computer will totalize the quantities measured during the serial test to the normal counters. These are the commercial quantities.

If it is set to “non-custody transfer” then flow computer will measure, display, and totalize the quantities in a so-called “shadow” meter run. These quantities will not be intermixed with the commercial quantities but they will be available to calculate the differences in serial test.

Flow computer in any meter runs can be set as custody transfer or non-custody transfer.

The second parameter is the Master/Slave function in the serial test.

“Master” flow computer will instruct the “Slave” flow computer to start the serial test measurement; it will collect measuring data after the test finished and will prepare the comparison test report.

In case of two meter runs only any of the meter runs can be Master or Slave. In case of three or more meter runs one meter run is dedicated as Master by the piping connection. The Master meter run will be the one, which can be connected in series with any of the remaining meter runs. Obviously, in this case the flow computer of that meter run must be the "Master" flow computer.

You can set the duration of the comparison in the Master flow computer. After the specified time Uniflow-200 will prepare a protocol of comparison, an example of which is given below.

```

=====
==
Flow meter comparison report                               2011.03.30 11:36:27
=====
==

```

	Master meter run	Slave meter run	Deviation Slave vs. Master
[%]			
Stream No:	8	1	
Stream name:	Station M6	Station M5	
Duration [min]:	40		
Duration [cycle]:	4800		
Vline [m3]:	744.4532	739.3187	
Vline_@Master_PT [m3]:	744.4532	742.4711	-0.266
Vbase [m3]:	26780.7070	26709.4473	-0.266
Mass [kg]:	18828.0117	18777.9473	-0.266
Energy [GJ]:	921.3796	918.9277	-0.266
P_average [bar]:	33.2137	33.2627	
T_average [°C]:	9.3452	8.7678	
Zline_average [-]:	0.927525	0.926844	
Zbase_average [-]:	0.997923	0.997923	
qline_average [m3/h]:	1116.6809	1108.9769	
qline_average_@MastPT [m3/h]:	1116.6809	1113.7057	-0.266
qbase_average [Sm3/h]:	40171.0586	40064.1914	-0.266
qmass_average [kg/h]:	28242.0430	28166.9043	-0.266
qenergy_average [GJ/h]:	1382.0687	1378.3922	-0.266
Rel_dens_average [-]:	0.5737	0.5737	
Base_dens_average [kg/Sm3]:	0.7030	0.7030	
Line_dens_average [kg/m3]:	25.2914	25.3992	
Linedens_avg_@MastPT [kg/m3]:	25.2914	25.2913	-0.000
ICV_average [MJ/m3]:	34.4054	34.4054	
SCV_average [MJ/m3]:	38.1856	38.1856	
dP_average [mbar]:	0.0000	0.0000	
Average gas composition during the test [mole%]			
Nitrogen:	0.8457	0.8457	
Carbon-dioxide:	0.1874	0.1875	
H2S:	0.0000	0.0000	
H2O:	0.0000	0.0000	
Helium:	0.0000	0.0000	
Methane:	96.9947	96.9947	
Ethane:	1.3755	1.3756	
Propane:	0.4309	0.4309	
n_Butane:	0.0712	0.0712	
i_Butane:	0.0624	0.0624	
n_Pentane:	0.0098	0.0098	
i_Pentane:	0.0136	0.0136	
Hexan:	0.0052	0.0052	
Heptan:	0.0039	0.0038	
Octan:	0.0019	0.0019	
Nonan:	0.0000	0.0000	
Decan:	0.0000	0.0000	
Oxygen:	0.0000	0.0000	
CO:	0.0000	0.0000	

Hydrogen:	0.0000	0.0000
Argon:	0.0000	0.0000
Total:	100.0022	100.0023

=====

==

The sample report above shows results for 40 minutes comparison. The gas flows through the Slave meter run first. From the outlet of the Slave meter run interconnecting pipe section divert the flow to the inlet of the Master meter run.

The deviation is calculated for the

- volume and volume flow rate at line conditions;
- volume and volume flow rate at base conditions;
- mass and mass flow rate;
- energy and energy flow rate;
- line density at the pressure and temperature of the Master meter run.

Important to note that volume at line conditions measured by the Slave meter run is converted to the volume at line conditions valid at the pressure and temperature of the Master meter run. Only after such a conversion, the two volumes allowed to be compared.

Pressure in the Master meter run slightly lower (because of the pressure loss created by the valves, fitting, etc. located between the Slave and the Mater meter run) and the temperature is slightly higher (the gas is warming up in the above ground pipe sections).

Interesting to note that deviation of the volumes, mass and energy are all equal, - 0.266 %, and the deviation of the line density is 0.000 %. It shows that the pressure and temperature measurement, the compression factor calculation and all the calculations performed in the flow computer introduce neglectable error, compared to the deviation in the volume flow measurement of the two flow meters.

Carrying out comparison on periodic basis enables the operator to identify the drift in the flow meters and/or transmitters during normal operation of the measuring station, and thereby prevent the loss associated with the inaccuracy of measurement.